

REPLACING THE CUTTING STRIP ON SILHOUETTE AND CRAFT ROBO

1 Removing the Cutting Strip from the Cutter

- (1) Disconnect the power cable and the USB cable from the cutter.

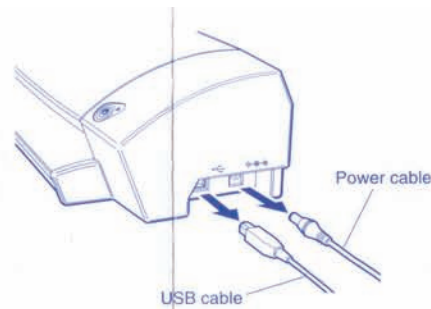

- (2) Open the cover and remove the blade assembly from blade assembly holder.

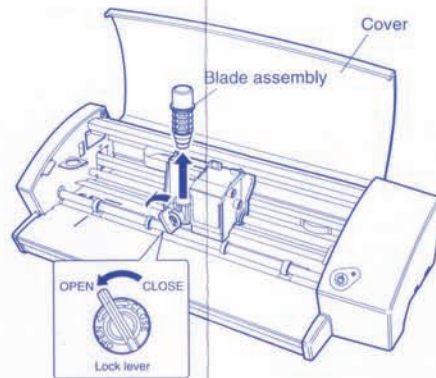

- (3) Move the cutting head to the right-hand side of the cutter.

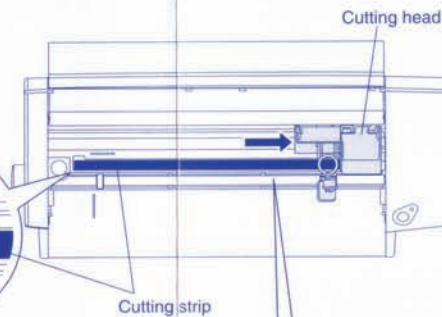

- (4) Peel off the cutting strip.



- (5) Use alcohol or other glue removers to wipe off any residual adhesive or debris from the area where the cutting strip was affixed.



2 Affixing a New Cutting Strip

- (6) Peel back approximately half off the release liner, and fold it as shown in the illustration.

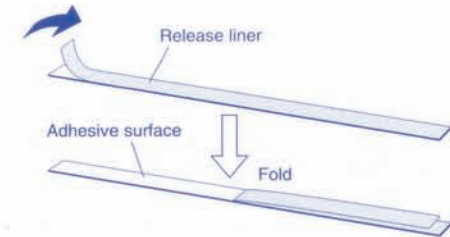

- (7) Affix the side from which the release liner was removed (adhesive side down) along the front edge of the groove, leaving a 0.04" gap at the left edge of the groove.

CAUTION

When affixing the cutting strip, make sure that it is completely flat and straight. A cutting strip that is uneven or curved may be the cause of incomplete cutting or malfunctions.

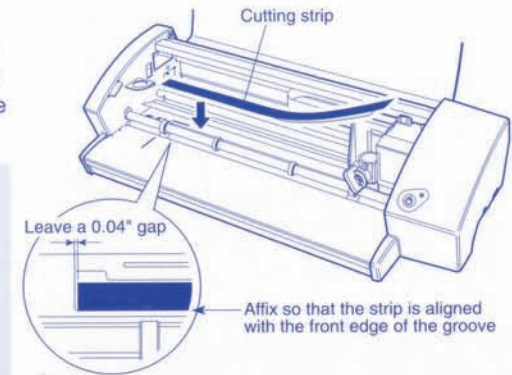

- (8) Pass the right end of the cutting strip underneath the cutting head, and then move the cutting head to the left-hand side of the cutter.

CAUTION

Take care that the cutting strip and release liner do not get caught up in the cutting head.

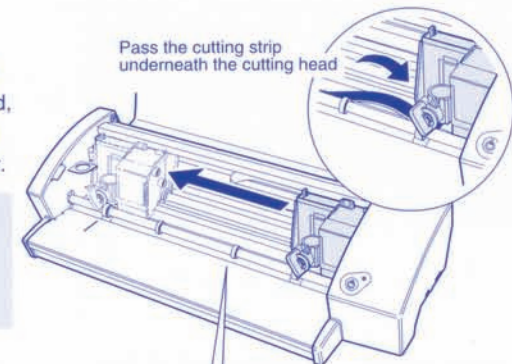

- (9) Peel off all of the release liner, and then affix the rest of the cutting strip in the groove. This completes the replacement operation.

